



IBT 100-VEL

100 l planetary mixer, stainless steel safety cover, with electronic speed variator (20 –215 rpm). Lifting system for Up/Down bowl. Oil-less planetary system. 7" Touchscreen panel for controlling machine. Equipped with spiral hook, paddle, whisk. Bowl with wheels.

IBT 100-VEL CR

100 l planetary mixer, stainless steel safety cover, with electronic speed variator (20 –215 rpm). Lifting system for Up/Down bowl. Oil-less planetary system. 7" Touchscreen panel for controlling machine. Equipped with spiral hook, paddle, whisk. Bowl with wheels. AISI 304 Stainless Steel body.

Specification

Floor model, suitable for all kneading, mixing and whipping operations. Body painted with corrosion resistant electrostatically paint or AISI 304 stainless steel option. 7" Touchscreen control panel. Lifting system for Up/Down bowl automatically. Equipped with 100 l capacity stainless steel AISI 304 bowl. Powerful asynchronous motor with electronical speed variator. Water protected planetary system. Stainless steel bowl guard. Bowl position device allows the mixer to switch on only when the bowl and safety cover are properly positioned together.

Included Accessories

- 1 of Bowl 100 l mixer
- 1 of Spiral Hook 100 l
- 1 of Paddle 100 l
- 1 of Whisk 100 l
- 1 of Scraper 100 l



Main Features

- IBT Series planetary mixers provide very intensive, quick, homogeneous and dead spot free mixing . Professional beater mixer that provides all the basic mixer functions; kneading of all sort of pastes, mixing of semi-liquid products, emulsions and various sauces.
- Dirmak accessories are designed for long-term usage under heavy duty conditions. Mixer is equipped with spiral hook, paddle, wire whisk and mixing bowl for 100 l.
- Electronic speed variator.
- 7" Touch screen control panel
- Scraper equipped
- Maximum capacity (Flour, with %60 hydration) 25 kg, suitable for 315-1000 meals per service.
- Wire safety cover enable to add products while working, thus ensuring operator safety.
- Raising and lowering of the bowl controlled by lifting system with an automatic locking of the bowl when in the raised position.
- Lifting system with motor
- Bowl with wheels
- Safety device will automatically stop the machine when the bowl is lowered.
- Stainless steel bowl guard prevents operation when front portion of guard is out of position.
- Covering the stainless steel wire one, limits the flour and unsafe dust particles when used in bakery and pastry preparation.

Construction

- Body painted with corrosion resistant electrostatic paint or AISI 304 Stainless steel option.
- AISI 304 Stainless steel bowl—100 l capacity.
- Asynchronous motor with high start-up torque.
- Water protected planetary system (IP54 electrical controls, IP 32 overall machine)
- Power :5,5 + 0,55 kW for IBT 100-VEL
5,5 + 0,55 kW for IBT 100-VEL CR
- Planetary movement based on belt driven oil-less planetary system.

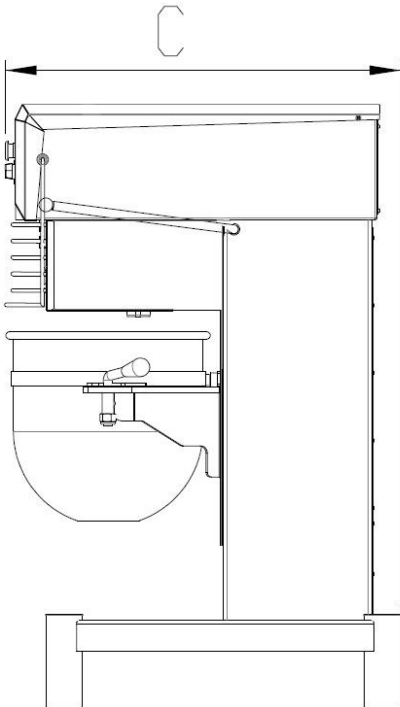
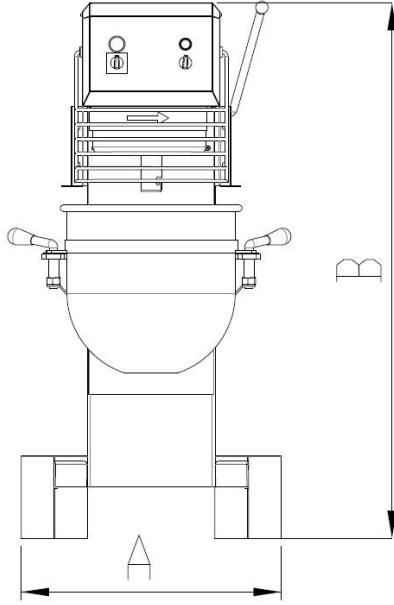

Electric

Supply Voltage :

IBT 100-VEL 380-415 V/3P/50-60Hz

IBT 100-VEL CR 380-415 V/3P/50-60Hz

Electrical Power Max. :

IBT 100-VEL 5,5 + 0,55kW

IBT 100-VEL CR 5,5 + 0,55kW

Capacity

Performance (Up to) : 25 Kg / Cycle

Capacity : 100 litre

Key Information

Width (A) : 1350 mm

Height (B) : 2100 mm

Depth © : 1500 mm

Shipping Weight : 600 Kg

Cold Water Paste : 25 Kg with Spiral Hook

Egg Whites : 200 pcs with Whisk

