



IBT 200-VEL 200 l planetary mixer, stainless steel safety cover, with electronic speed variator (20 –245 rpm). Lifting system for Up/Down bowl. Oil-less planetary system. 10" Touchscreen panel for machine control. Leakproof cover for bowl. Safety cover for bowl movement. Equipped with spiral hook, paddle, whisk and scraper. Bowl with wheels.

Specification

Floor model, suitable for all kneading, mixing and whipping operations. Body painted with corrosion resistant electrostatically paint or AISI 304 stainless steel option. Equipped with 200 l capacity stainless steel AISI 304 bowl. Powerful asynchronous motor with electronic speed variator. Water protected planetary system. Stainless steel bowl guard. Water proof 10" touchscreen control panel. Bowl position device allows the mixer to switch on only when the bowl and safety cover are properly positioned together.

Included Accessories

- 1 of Bowl 200 l mixer
- 1 of Spiral Hook 200 l
- 1 of Paddle 200 l
- 1 of Whisk 200 l
- 1 of Scraper 200 l



Main Features

- IBT Series planetary mixers provide very intensive, quick, homogeneous and dead spot free mixing . Professional beater mixer that provides all the basic mixer functions; kneading of all sort of pastes, mixing of semi-liquid products, emulsions and various sauces.
- Dirmak accessories are designed for long-term usage under heavy duty conditions. Mixer is equipped with spiral hook, paddle, wire whisk and mixing bowl for 200 l.
- Electronic speed variator.
- Leakproof bowl cover causes more efficient mixing results.
- 10" Touch screen control panel.
- Optionally recipe system.
- Scraper equipped.
- Discharge valve for bowls.
- Maximum capacity (Flour, with %60 hydration) 60 kg, suitable for 600-2000 meals per service.
- Raising and lowering of the bowl controlled by lifting system with an automatic locking of the bowl when in the raised position.
- Lifting system with motor.
- Bowl with wheels.
- Safety device will automatically stop the machine when the bowl is lowered.
- Stainless steel bowl guard prevents operation when front portion of guard is out of position.

Construction

- Body painted with corrosion resistant electrostatic paint
- AISI 304 Stainless steel bowl 200 l capacity.
- Asynchronous motor with high start-up torque.
- Water protected planetary system (IP54 electrical controls, IP 32 overall machine)
- Power : 11,0 + 0,75 kW for IBT 200-VEL
- Planetary movement based on belt driven oil-less planetary system.

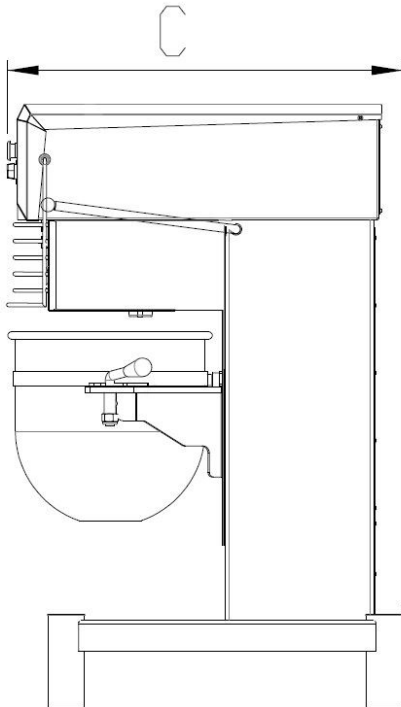
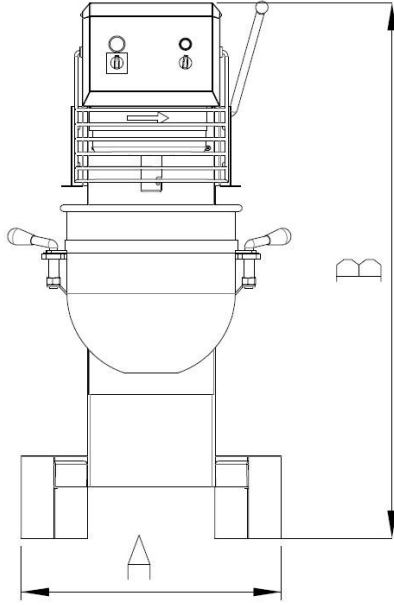

Electric

Supply Voltage :

IBT 200-VEL 380-415 V/3P/50-60Hz

Electrical Power Max. :

IBT 200-VEL 11,0 + 0,75kW

Capacity

Performance (Up to) : 60 Kg / Cycle

Capacity : 200 litre

Key Information

Width (A) : 1400 mm

Height (B) : 2350 mm

Depth (C) : 1750 mm

Shipping Weight : 2200 Kg

Cold Water Paste : 60 Kg with Spiral Hook

Egg Whites : 400 pcs with Whisk

